

# DL SERIES

## SUBMERSIBLE PUMPS WITH ENTRAINED SOLIDS WASTE WATER

DL series electric pumps are available with single-channel or Vortex impeller (DLV).

Designed to handle with entrained solids wastewater, with head up to 21 m and delivery up to 120 m<sup>3</sup>/h.

### APPLICATIONS

- Pumping of sewage with suspended solids and filaments.
- Emptying of sumps, septic tanks and wastewater discharge tanks.
- Draining of flooded excavations and marshy ground.

### SPECIFICATIONS

- Squirrel cage **motor** in a dielectric non-toxic **oil cooled**, which ensures the lubrication of the ball bearings and more efficient cooling.
- **2-pole** (0.6 to 1.5 kW) and **4-pole** (1.8 to 4 kW) motors.
- **Mechanical seal** protected by **sand labyrinth**.
- Maximum immersion depth: 5 m.
- **IP 68 protection**.
- **Maximum temperature of pumped liquid: 50°C with fully submerged pump. 25°C with partially submerged pump.**
- **Passes solids up to:**  
**45 mm (DL 80, 90, 105, Minivortex, Vortex).**  
**50 mm (DL 109, 125, 160, DLV 100, 115).**  
**60 mm (DL 180, 200).**  
**65 mm (DLV 120, 140, 160).**
- Versions:  
**Single-phase** 220-240 V 50 Hz, with built-in automatic reset overload protection and capacitor box with on/off switch.  
**Three-phase** 220-240 or 380-415 V 50 Hz for pumps up to 4 kW.  
 Overload protection to be provided by user (installed in the control box).
- Pre-assembled float available on request (single-phase versions DL...CG, DLV...CG).



### TABLE OF MATERIALS

#### 2 POLES PUMPS: DL 80, 90, 105, 109, 125; MINIVORTEX and VORTEX, DLV 100, 115

PART	MATERIAL
Pump body	200 UNI ISO 185 CAST IRON*
Impeller	STAINLESS STEEL (AISI 304 - DIN 1.4301) 200 UNI ISO 185 CAST IRON* FOR MINIVORTEX AND VORTEX
Suction flange, Support feet, Shaft (extension), Motor casing	STAINLESS STEEL (AISI 304 - DIN 1.4301)
O-Ring	NITRILE RUBBER
Mechanical seal	CARBON/CERAMIC/ NITRILE RUBBER
Delivery seal (DL 109, 125 and DLV 100, 115)	200 UNI ISO 185 CAST IRON*

#### 4 POLES PUMPS: DL 160, 180, 200 and DLV 120, 140, 150

PART	MATERIAL
Pump body, Impeller, Motor-pump support	200 UNI ISO 185 CAST IRON*
Shaft	STAINLESS STEEL (AISI 420 - DIN 1.4021)
Motor casing, Motor cover, Handle tie rod with bracket, Base	STAINLESS STEEL (AISI 304 - DIN 1.4301)
Mechanical seal	TUNGSTENE CARBIDE/ TUNGSTENE CARBIDE/ PPM
O-Ring	NITRILE RUBBER

\* Cast iron coated with polybutadiene varnish by electrophoresis at 180°C.

## DL SERIES (SINGLE-CHANNEL IMPELLER) OPERATING CHARACTERISTICS AT 2850 rpm 50 Hz

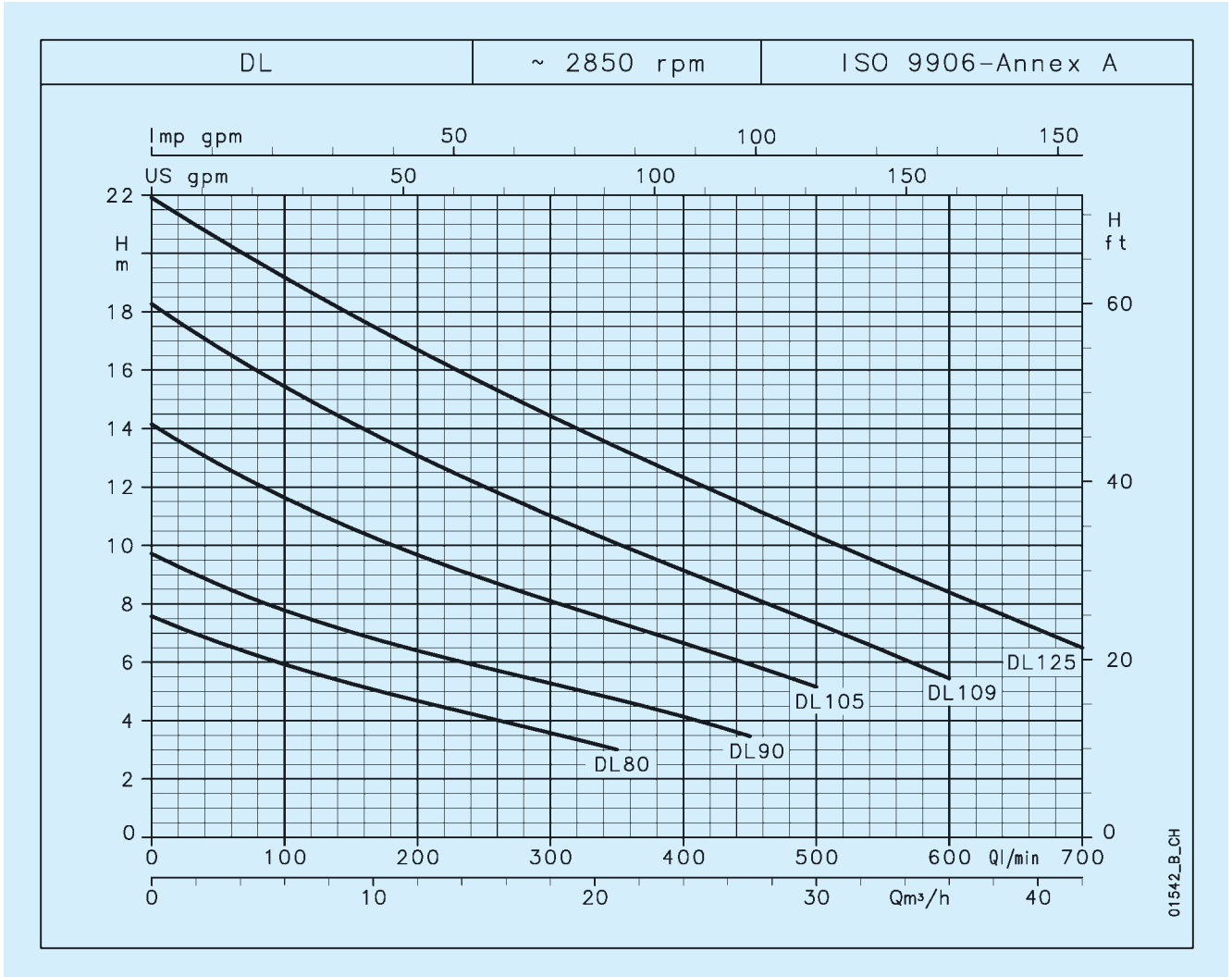

PUMP TYPE	RATED POWER		Q = DELIVERY												
			l/min	0	100	150	200	250	300	350	400	450	500	600	700
			m <sup>3</sup> /h	0	6	9	12	15	18	21	24	27	30	36	42
	kW	HP	H = TOTAL HEAD METERS COLUMN OF WATER												
DL(M) 80	0.6	0.8	7.6	5.9	5.3	4.7	4.1	3.6	3.0						
DL(M) 90	0.6	0.8	9.7	7.8	7.0	6.4	5.8	5.3	4.7	4.1	3.5				
DL 105	1.1	1.5	14.1	11.6	10.6	9.7	8.9	8.1	7.4	6.7	5.9	5.2			
DL(M) 109	1.1	1.5	18.3	15.4	14.2	13.1	12.0	11.0	10.1	9.2	8.2	7.3	5.4		
DL 125	1.5	2	21.9	19.2	17.9	16.7	15.5	14.4	13.4	12.3	11.3	10.3	8.4	6.5	

These performances are valid for liquids with density  $\rho = 1.0 \text{ kg/dm}^3$  and kinematic viscosity  $\gamma = 1 \text{ mm}^2/\text{sec}$ .

dl-2p50\_a\_th

PUMP TYPE	INPUT POWER*	INPUT CURRENT*	CAPACITOR
SINGLE-PHASE	kW	220-240 V A	$\mu\text{F} / 450 \text{ V}$
DLM 80	0.79	3.91	25
DLM 90	0.89	4.27	25
-	-	-	-
DLM109	1.55	6.87	35
-	-	-	-

PUMP TYPE	INPUT POWER*	INPUT CURRENT*	INPUT CURRENT*
THREE-PHASE	kW	220-240 V A	380-415 V A
DL 80	0.8	-	2.09
DL 90	0.92	3.81	2.2
DL 105	1.43	4.66	2.69
DL 109	1.54	5.44	3.14
DL 125	2.14	6.58	3.8

\* Maximum value in specified range

dl-2p50\_a\_te

**DL**

## DLV SERIES (VORTEX IMPELLER) OPERATING CHARACTERISTICS AT 2850 rpm 50 Hz

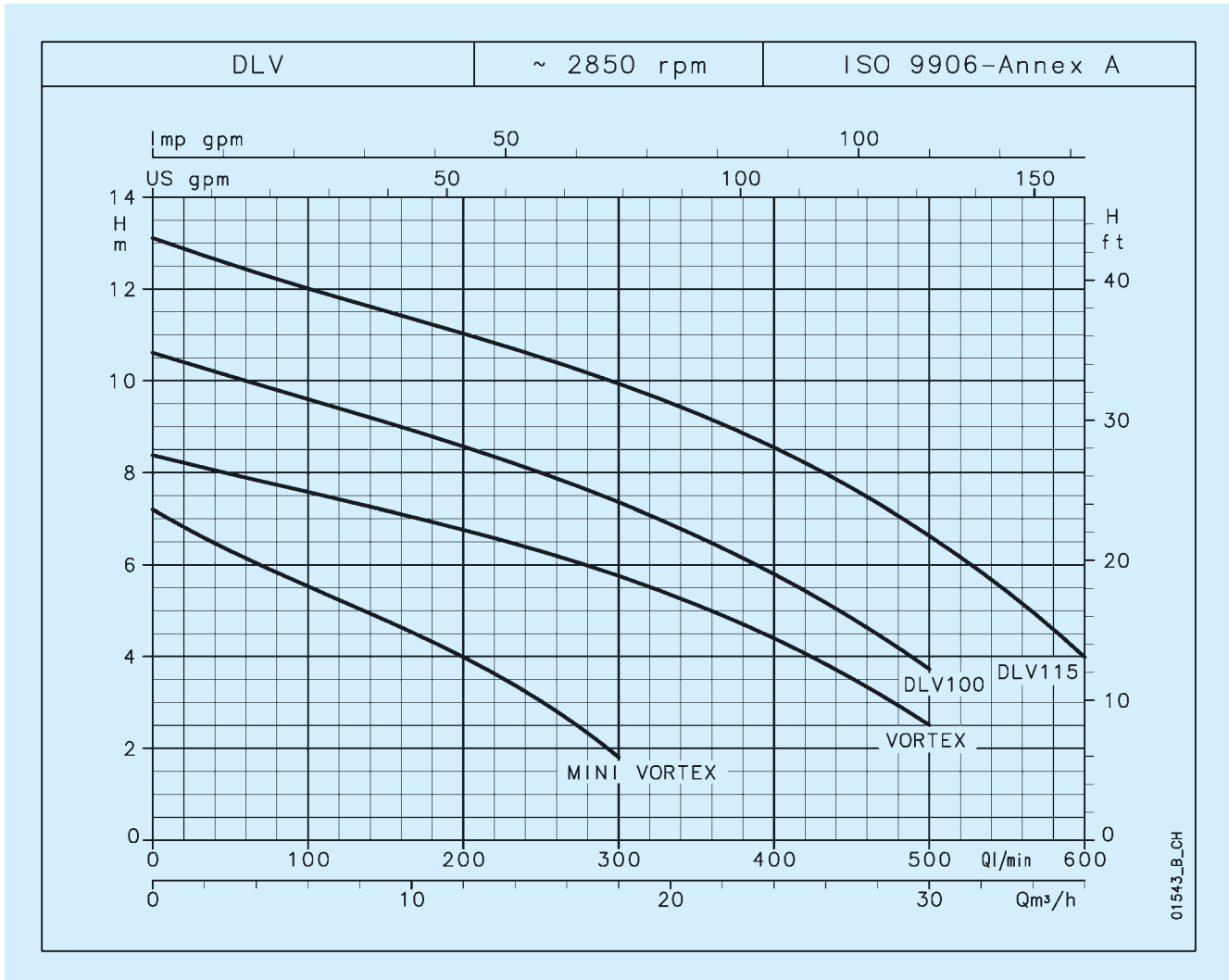

PUMP TYPE	RATED POWER		Q = DELIVERY												
			l/min	0	50	100	150	200	250	300	350	400	450	500	600
	kw	HP	m³/h	0	3	6	9	12	15	18	21	24	27	30	36
			H = TOTAL HEAD METERS COLUMN OF WATER												
MINI VORTEX(M)	0.6	0.8	7.2	6.3	5.5	4.8	4.0	3.0	1.8						
VORTEX	1.1	1.5	8.4	8.0	7.6	7.2	6.8	6.3	5.8	5.1	4.4	3.5	2.5		
DLV(M) 100	1.1	1.5	10.6	10.1	9.6	9.1	8.6	8.0	7.4	6.6	5.8	4.8	3.7		
DLV 115	1.5	2	13.1	12.5	12.0	11.5	11.0	10.5	9.9	9.3	8.5	7.7	6.6	4.0	

These performances are valid for liquids with density  $\rho = 1.0 \text{ kg/dm}^3$  and kinematic viscosity  $\gamma = 1 \text{ mm}^2/\text{sec}$ .

dlv-2p50\_a\_th

PUMP TYPE	INPUT POWER*	INPUT CURRENT*	CAPACITOR
SINGLE-PHASE	kw	220-240 V A	$\mu\text{F} / 450 \text{ V}$
MINI VORTEX M	1.05	4.82	25
-	-	-	-
DLVM100	1.64	7.30	35
-	-	-	-

PUMP TYPE	INPUT POWER*	INPUT CURRENT*	INPUT CURRENT*
THREE-PHASE	kw	220-240 V A	380-415 V A
MINI VORTEX	1.10	-	2.36
VORTEX	1.66	5.11	2.95
DLV 100	1.65	5.63	3.25
DLV 115	2.25	6.81	3.93

\* Maximum value in specified range

dlv-2p50\_a\_te



**SERIE DL (SINGLE-CHANNEL IMPELLER)  
OPERATING CHARACTERISTICS AT 1450 rpm 50 Hz**

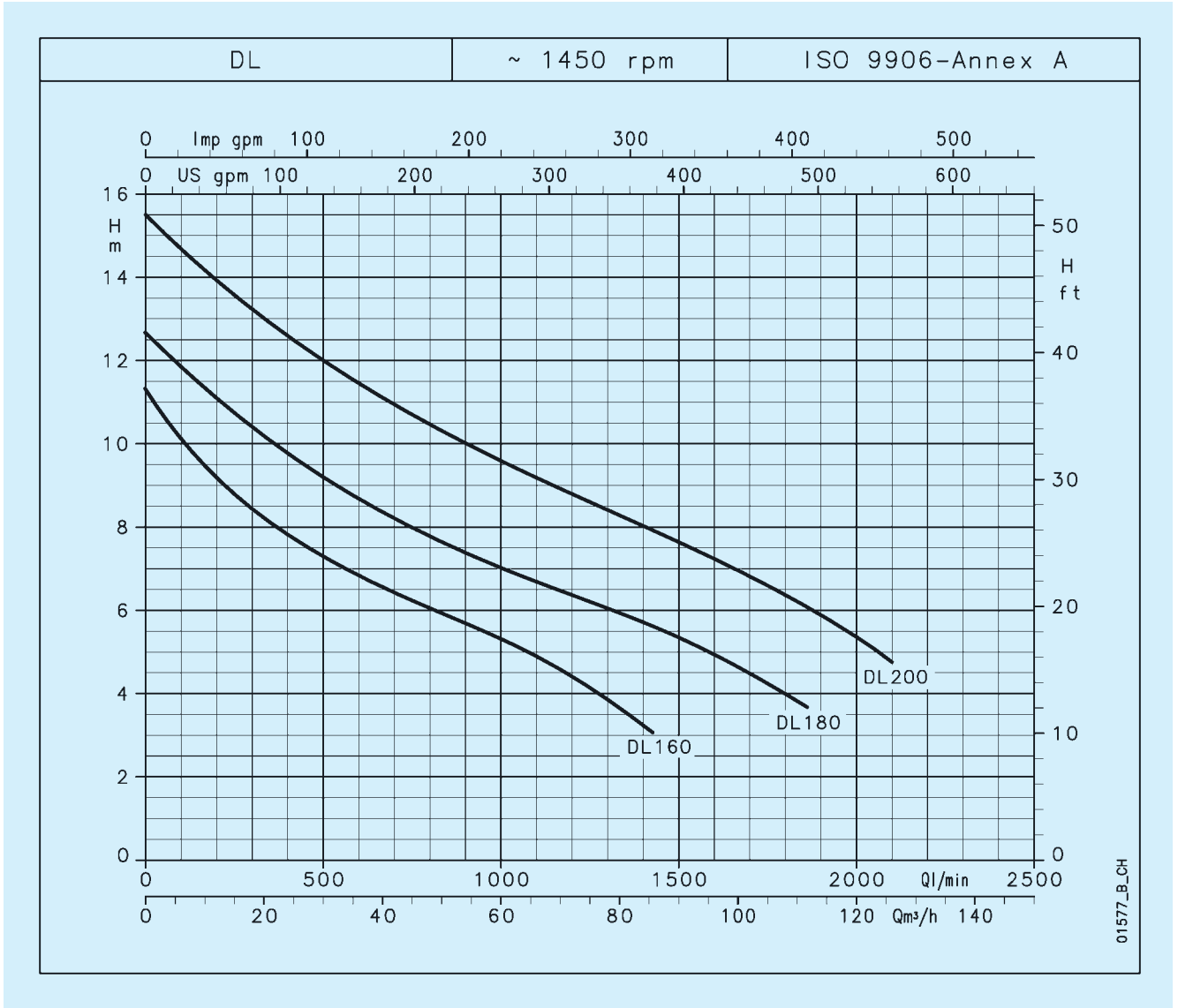

**DL**

PUMP TYPE	RATED POWER		Q = DELIVERY								
			l/min	0	500	750	1000	1250	1400	1750	2000
			m <sup>3</sup> /h	0	30	45	60	75	84	105	120
	kW	HP	H = TOTAL HEAD METERS COLUMN OF WATER								
DL 160	1.85	2.5	11.3	7.3	6.3	5.3	4.0				
DL 180	2.75	3.75	12.7	9.2	8.0	7.0	6.2	5.7	4.2		
DL 200	4	5.5	15.5	12.0	10.7	9.6	8.6	8.0	6.2	5.3	

These performances are valid for liquids with density  $\rho = 1.0 \text{ kg/dm}^3$  and kinematic viscosity  $\gamma = 1 \text{ mm}^2/\text{sec}$ .

dl4-4p50\_a\_th

PUMP TYPE	INPUT POWER*	INPUT CURRENT*	CAPACITOR
SINGLE-PHASE		220-240 V	
	kW	A	$\mu\text{F} / 450 \text{ V}$
-	-	-	-
-	-	-	-
-	-	-	-

PUMP TYPE	INPUT POWER*	INPUT CURRENT*	INPUT CURRENT*
THREE-PHASE		220-240 V	380-415 V
	kW	A	A
DL160	2.1	6	3.5
DL180	3.2	10	5.8
DL200	4.7	15	8.7

\* Maximum value in specified range

dl4-4p50\_a\_te

## DLV SERIES (VORTEX IMPELLER) OPERATING CHARACTERISTICS AT 1450 rpm 50 Hz

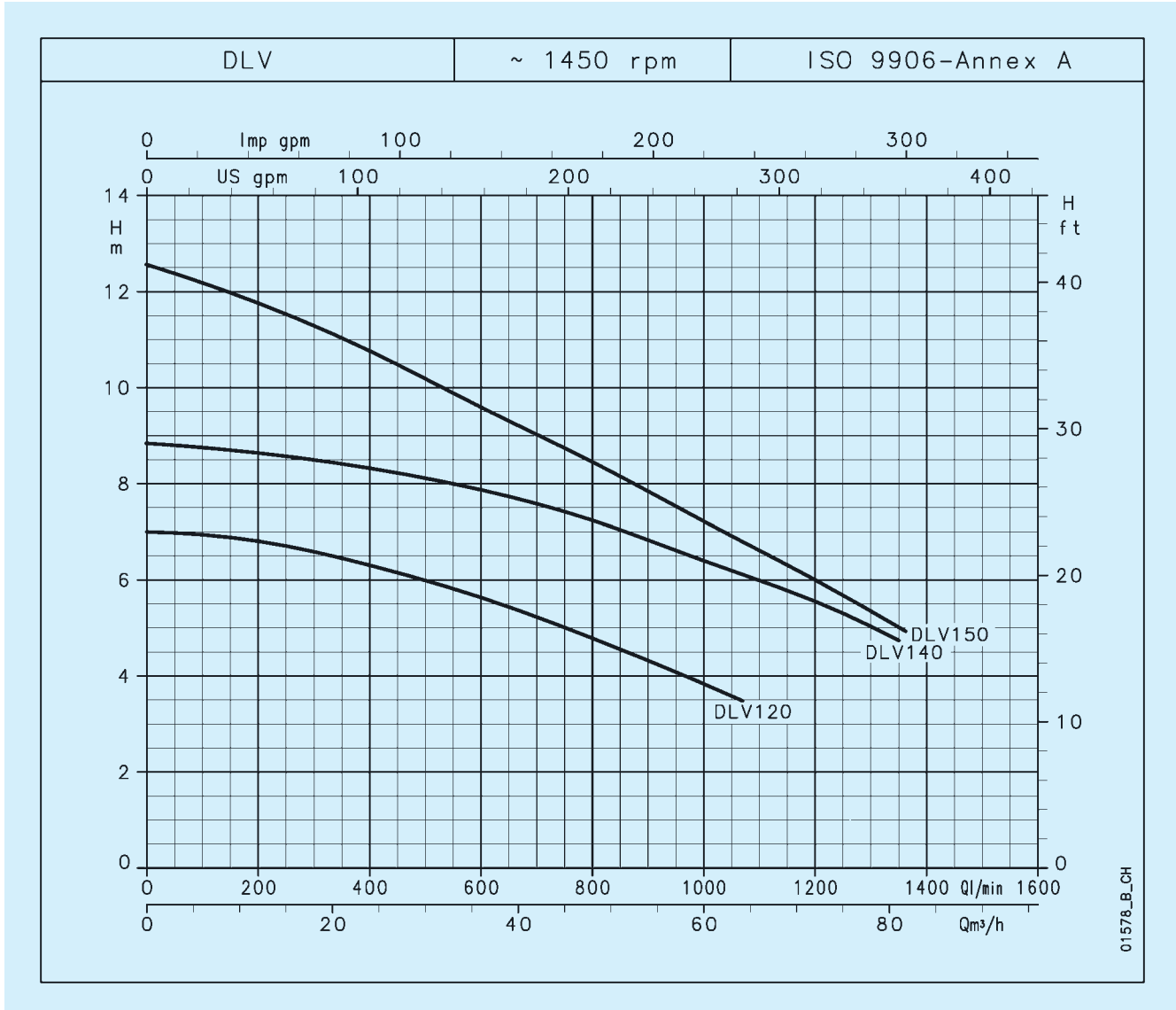

PUMP TYPE	RATED POWER		Q = DELIVERY							
			l/min	500	750	1000	1250	1400	1750	2000
			m <sup>3</sup> /h	30	45	60	75	84	105	120
		H = TOTAL HEAD METERS COLUMN OF WATER								
	kW	HP	7.0	6.7	6.0	5.0	3.8			
DLV 120	1.85	2.5	7.0	6.7	6.0	5.0	3.8			
DLV 140	2.75	3.75	8.8	8.6	8.1	7.4	6.4	6.0	5.3	4.7
DLV 150	4	5.5	12.5	11.5	10.2	8.7	7.2	6.6	5.7	5.0

These performances are valid for liquids with density  $\rho = 1.0 \text{ kg/dm}^3$  and kinematic viscosity  $\gamma = 1 \text{ mm}^2/\text{sec}$ .

dlv-4p50\_a\_th

PUMP TYPE	INPUT POWER*	INPUT CURRENT*	CAPACITOR
SINGLE-PHASE		220-240 V	
	kW	A	$\mu\text{F} / 450 \text{ V}$
-	-	-	-
-	-	-	-
-	-	-	-

PUMP TYPE	INPUT POWER*	INPUT CURRENT*	INPUT CURRENT*
THREE-PHASE		220-240 V	380-415 V
	kW	A	A
DLV120	2.3	7.8	4.5
DLV140	3.4	11.2	6.5
DLV150	4.9	16.5	9.5

\* Maximum value in specified range

dlv-4p50\_a\_te



## 2 POLES DL(V) SERIES DIMENSIONS AND WEIGHTS

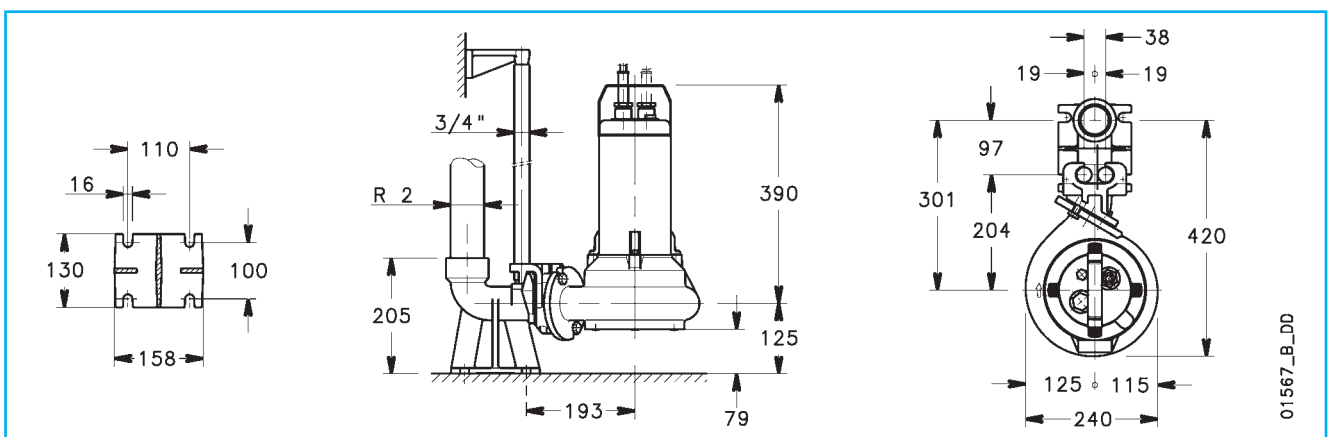
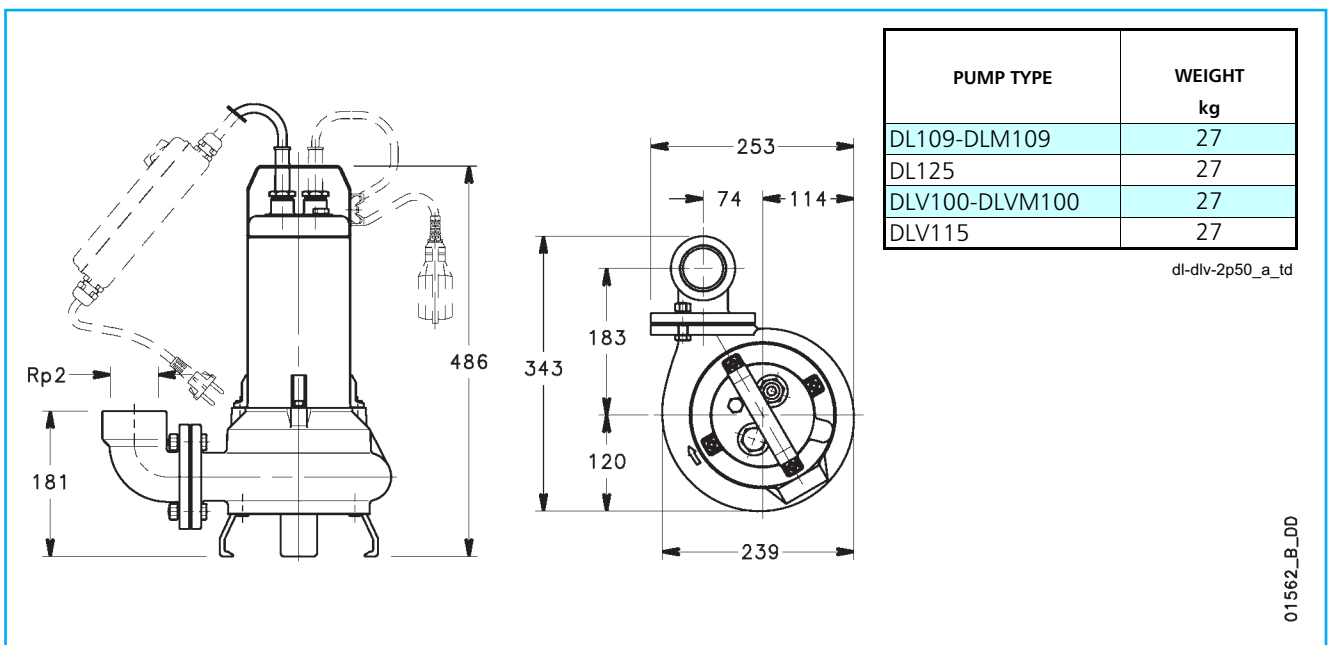
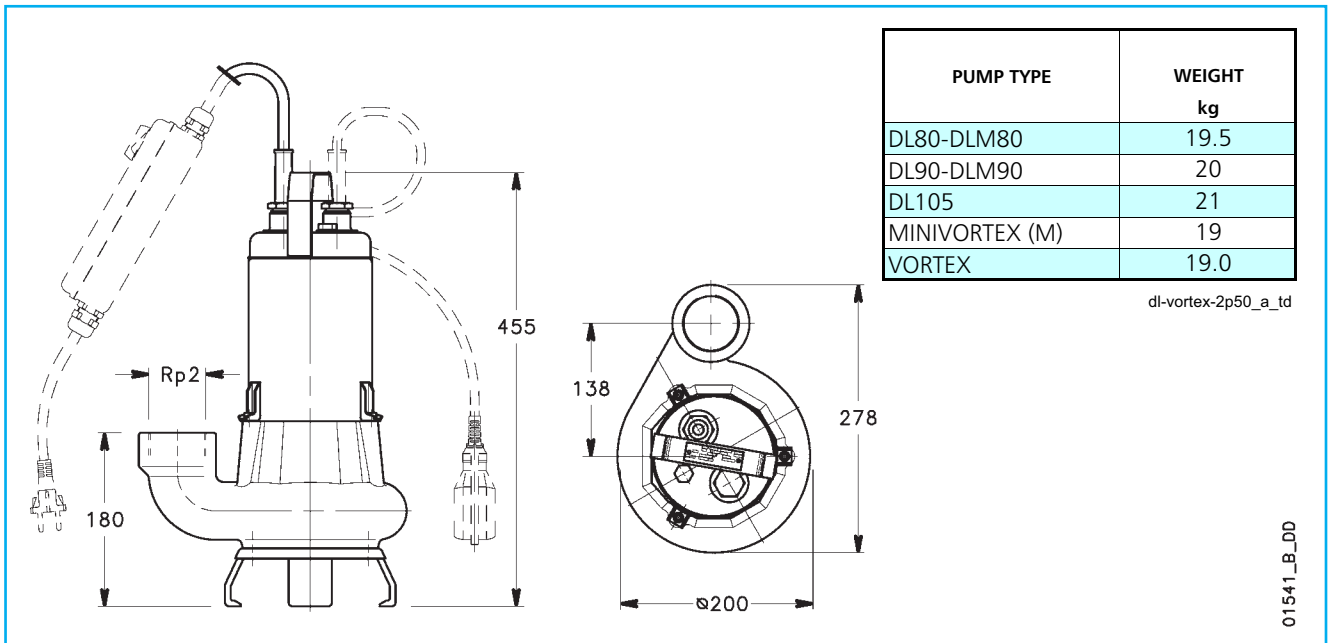

DL

## 4 POLES DL(V) SERIES DIMENSIONS AND WEIGHTS

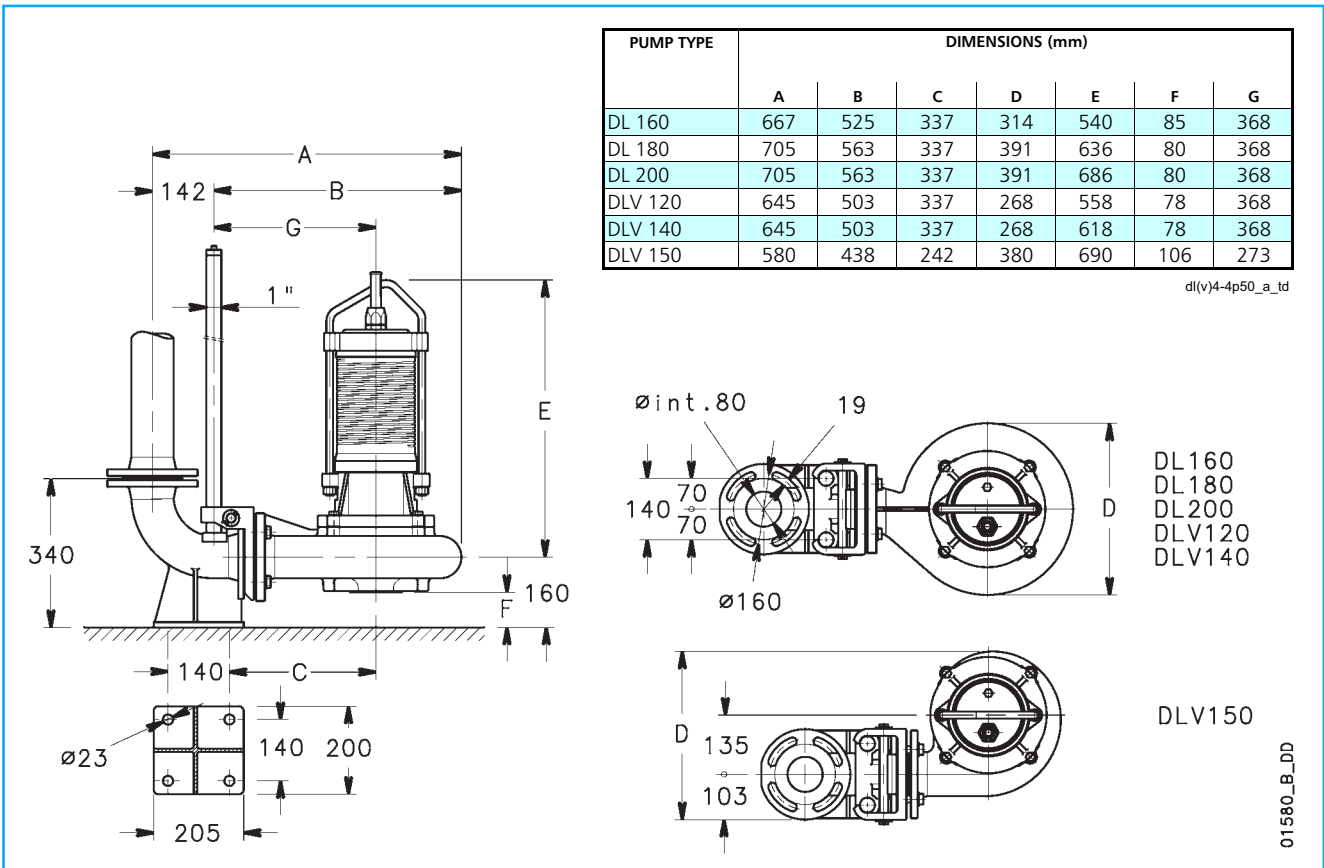
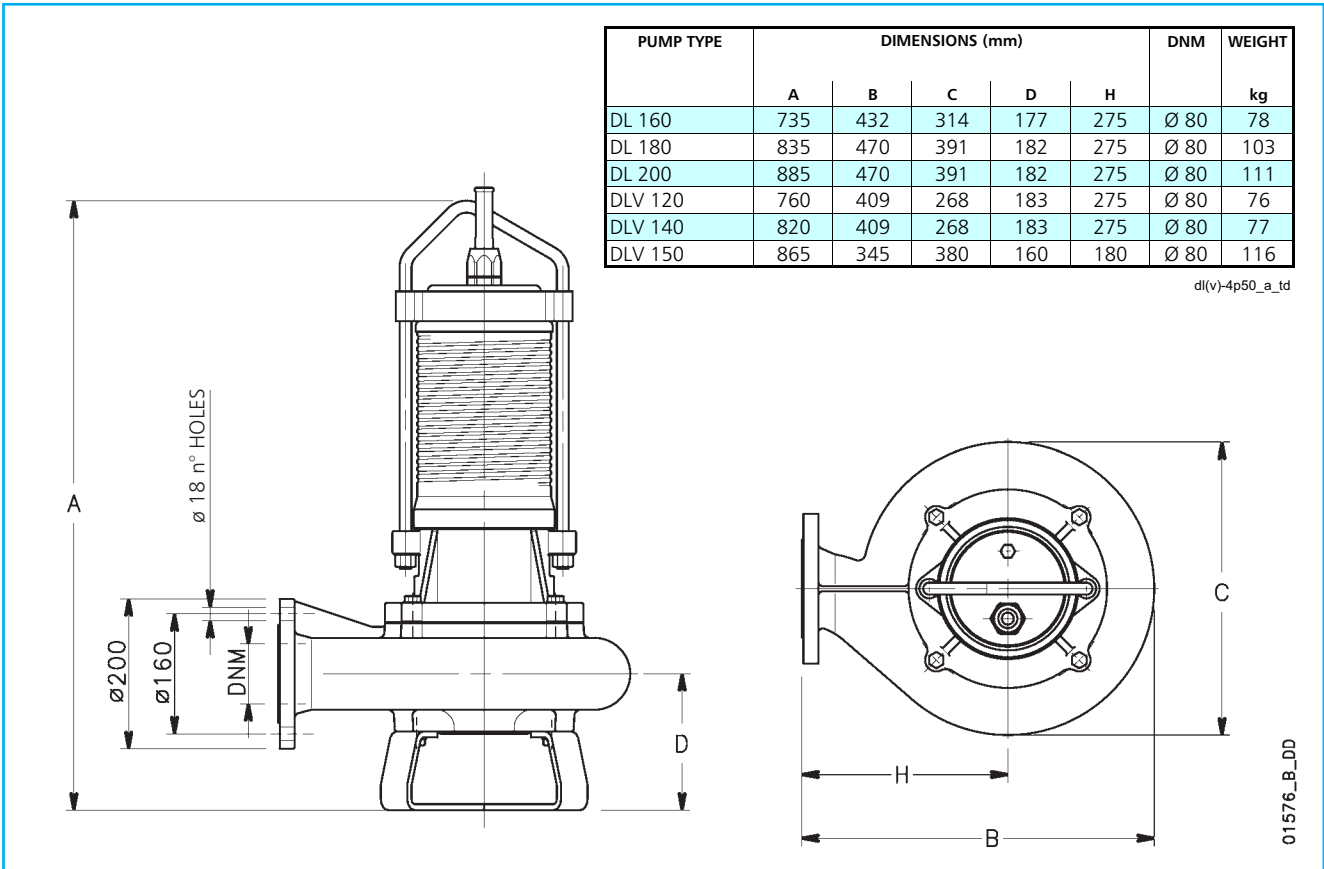

DL